

### IMPORTANT: READ ALL INSTRUCTIONS BEFORE PROCEEDING WITH INSTALLATION

## General

The following guidelines provide basic assembly and installation instructions for aluminum canopies mounting to grout-filled concrete masonry (CMU) building conditions. The ACP-802 is designed to withstand a downward pressure up to 50 psf and an upward pressure of 30 psf.

1. Refer to the site specific submittal drawings for details regarding component location relative to the building when provided.
2. Installer must protect from water ingress into the building. Apply silicone sealant as required to completely seal any hardware penetrations through the building fascia.

NOTE: Brick fascia shown, other building fascia similar.

## Preparation

### Components

1. Locate all crates, boxes, cartons, etc.
2. Remove canopy sections from packaging, inspect for damage, confirm quantities and sizes with packing list, and organize parts in order of installation. Installation hardware will be packaged in a separate box if purchased.
3. Notify your All-Lite representative immediately of any shortages or shipping damage.

### Site Review

1. Inspect building against the site specific submittal drawings if included for accuracy. Verify that the canopies will fit.

## Customer Supplied Items

- Silicone Sealant (for sealing anchor support tubes to building fascia.)
- Flashing and Sealant (to prevent water damage between canopy body and building.)
- Gutter Sealant (for sealing field installed gutters if supplied.)

## Recommended Tools

- Scissor Lift (to lift canopy bodies)
- Chop Saw or Other (for cutting aluminum tube spacers)
- Power Driver (for drills and drivers)
- 10 oz Cartridge Caulk Gun
- Hilti MD2500 Dispenser
- 1-1/8" Combination Wrench
- 7/16" (Qty 2) Combination Wrenches
- 9/16" (Qty 2) Combination Wrenches
- 3/8" & 5/16" Hex Driver
- #20 Torx Driver
- 1-1/8" & 7/32" & 11/16" Masonry Drill Bit
- 5/8" & 3/16" & 5/16" & 0.397 (x drill size) & 9/16" Standard Drill Bit
- 8" Soft Jaw Clamps (Irwin Woodworking Type) (Qty 2)
- 12 ft & 50 ft Tape Measure
- Rubber Non-Marring Mallet
- Chalk Line
- 4 ft Level
- Marker

## Installation

### Install Canopy Anchors

1. The canopy sections and tie-back rods require that anchors penetrate a building fascia and affix to a grout filled CMU condition that has been properly designed to support the load required by the site.
2. Refer to site specific submittal drawings for mounting rail/anchor locations. Using a chalk line, mark a line parallel to a line on the building that will locate the bottom of the mounting rails. Using the mounting rails as a template, mark anchor locations on the building. See Figure 1.1. Anchors are required at the 2 outer holes of each mounting rail. Similar to the mounting rails, mark anchor locations for all the tie-back rod brackets. A template is provided for the marking of these holes.

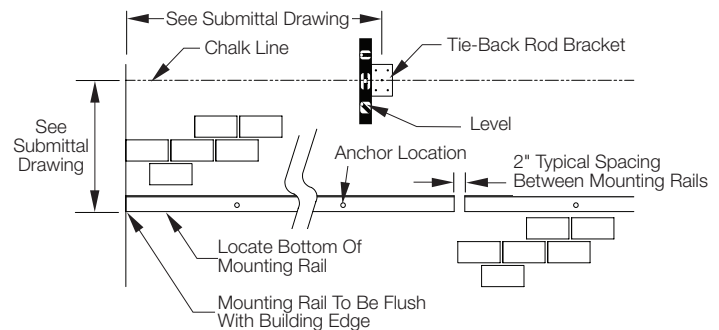


Fig 1.1 Mounting Rail

3. Drill 11/16" holes 8-8-1/2" deep (thru the building fascia and into the CMU) at anchor locations. Using the 11/16" holes as a guide, drill thru the building fascia only using a 1-1/8" masonry drill.
4. Install anchors using adhesive per supplied Hilti instructions. Anchors should be set to protrude 1-1/4" from the face of the building fascia. The anchor support tubes are to be installed and affixed in place by silicone sealant. Anchor support tubes are intentionally longer than required so that the installer can trim flush to the face of the building fascia, mark support tube, cut, then reinstall and caulk. See Figures 1.2 and 1.3.

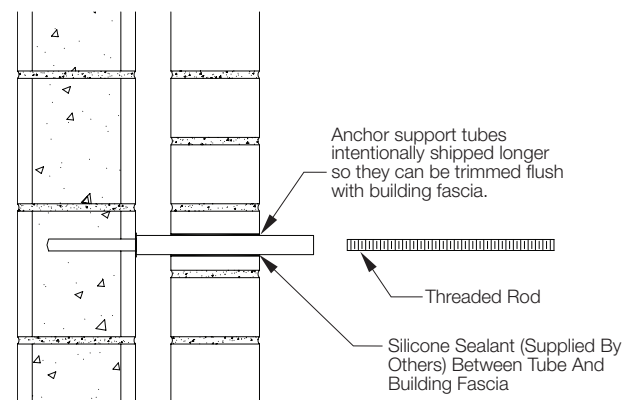


Fig. 1.2 Support Tube Installation

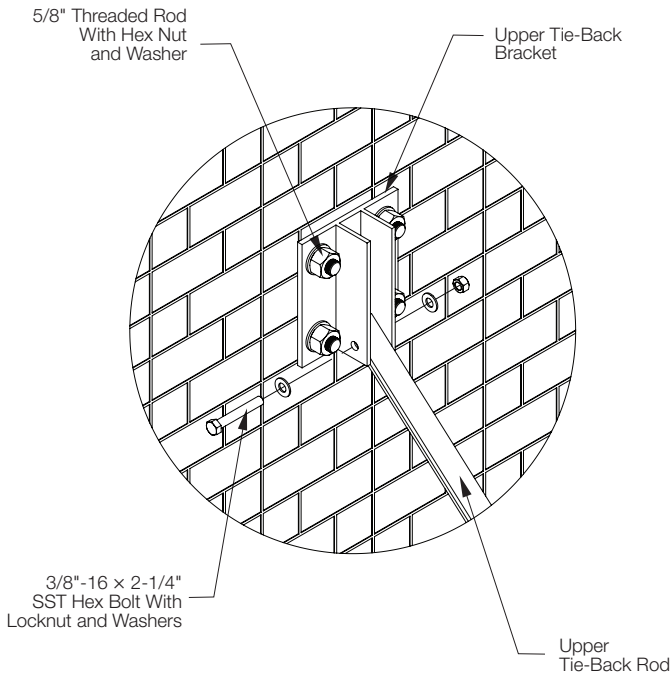
# Installation Details

## ACP-802 Aluminum Canopy Installation Instructions - CMU Building Condition

### Installation

Install Canopy Anchors (continued from page 1)

- After the anchors and anchor support tubes are secured in place, the mounting rails can be installed. The mounting rails should be shimmed so that they are straight within 1/8" along the entire length of the system. Initially finger tighten hardware; after alignment of all mounting rails, securely tighten anchor hardware. See Figure 1.3.
- Install tie-back rod brackets to the building condition and fully tighten anchor hardware. See Figure 2.1



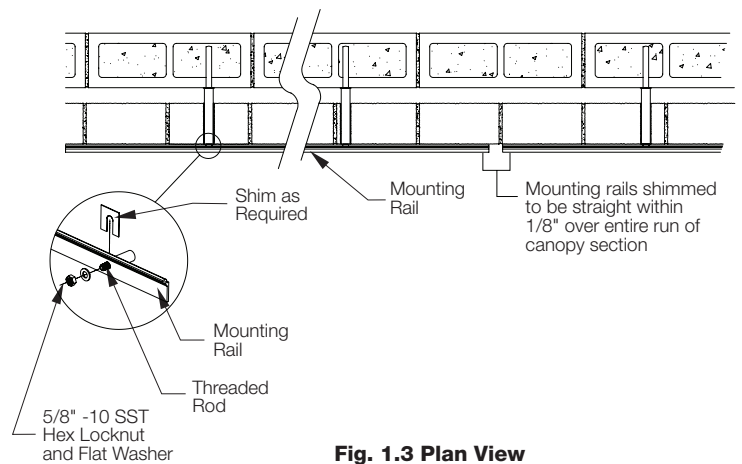
**Fig. 2.1 Support Tube Installation**

Install Tie-Back Rods

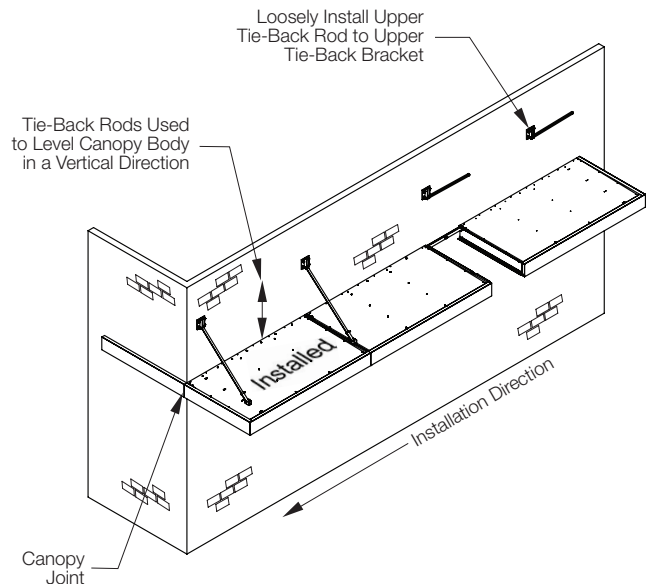
- Loosely install, but don't fully tighten, the upper tie-back rods to the upper tie-back brackets with the supplied 3/8-16 x 2-1/4" hex bolts, locknuts and washers.

Install Canopy Systems

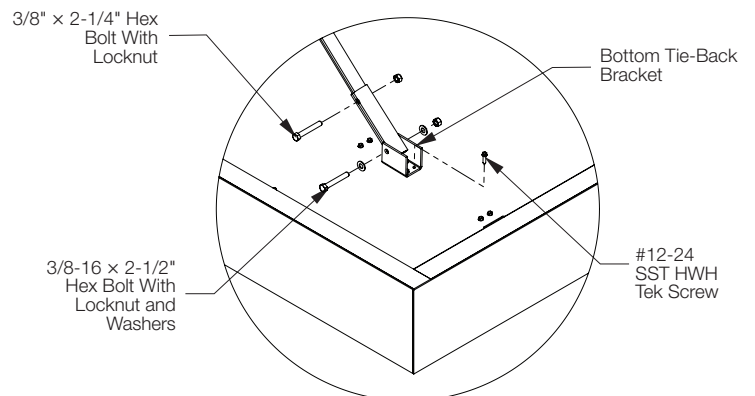
- Canopy systems can consist of a single stand-alone unit or a stand-alone system consisting of multiple canopy sections. Multiple sections should always be installed from left to right. See Figure 3.1.
- IMPORTANT:** See submittal drawing to determine sequence of canopy body installation. Not following the proper installation sequence can cause misalignment of some components.
- Left end sections, right end sections and single section canopy systems have tie-back brackets that attach to support tubes 12" from the outside edge. Locate and install the appropriate bottom tie-back brackets onto the tubes of these sections using existing holes and #12 TEK screws supplied. Fully tighten tie-back hardware. See Figure 3.2.
- Carefully lift the left-most canopy section into place ensuring that it securely registers into the top of the mounting rail and is flush with the building corner if a corner is present. Level the front of the canopy section.



**Fig. 1.3 Plan View**



**Fig. 3.1 Typical Installation**

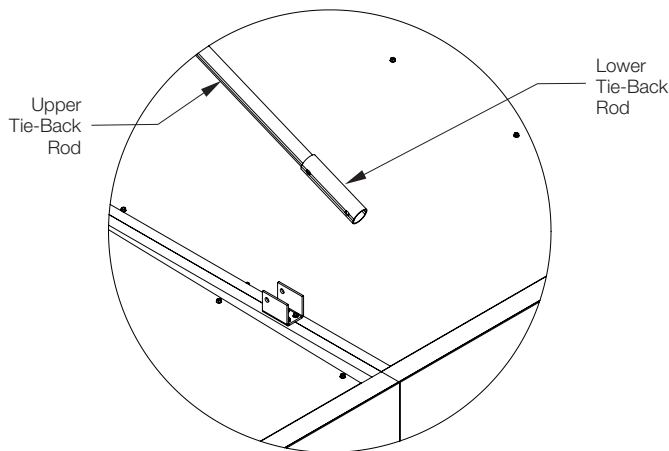


**Fig. 3.2 Canopy Section Installation**

## Installation

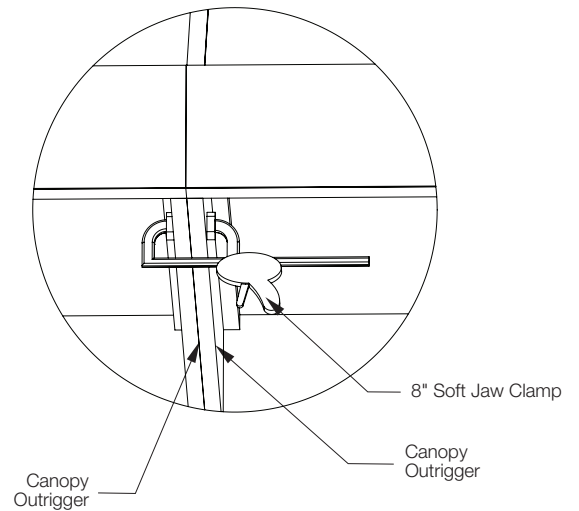
Install Canopy Systems (continued from page 2)

- The tie-back system consists of a lower tie-back rod that slips over an upper tie-back rod. Using the lower tie-back rod as a guide, holes need to be drilled into the upper tie-back rod. This allows for adjustability at the face of the canopy.
- Slip the larger lower tie-back rod over the upper tie-back rod (already loosely installed). See Figure 3.3. Position the tie-back rod so it fits into the lower tie-back bracket and loosely bolt the rod in place using the supplied 3/8-16 x 2-1/2" hex bolts, locknuts and washers. See Figure 3.2.

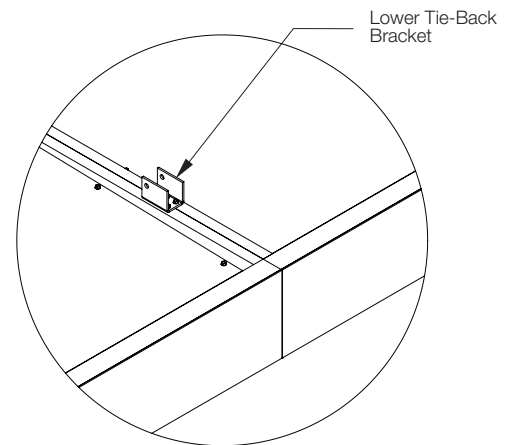


**Fig. 3.3 Tie-Back Rod Assembly**

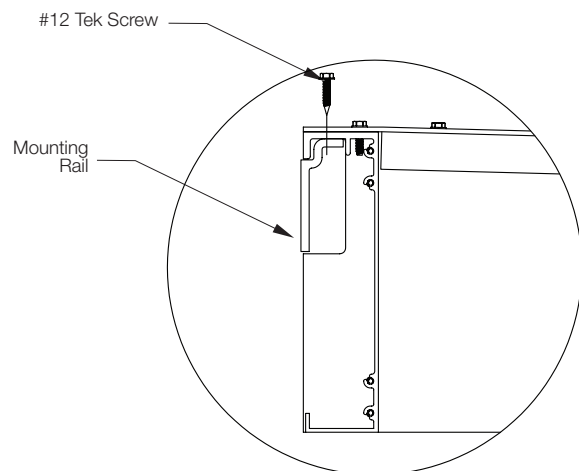
- Once the lower tie-back rod is loosely secured in the lower tie-back bracket, make sure the front of the canopy section remains level. With the front of the canopy level, using the holes in the lower tie-back rod as guides, drill a 0.397" hole. (X Drill Size) through **ONE SIDE ONLY** of the upper tie-back rod. Repeat on the other side of the tie-back rod. Use the supplied 3/8-16 x 2-1/4" hex bolts and locknuts supplied to fasten the upper and lower tie-back rods together. See Figure 3.2. Fully tighten hardware.
- For single section canopy systems, repeat steps 6 and 7 on the right side of the system.
- For multiple section canopy systems carefully lift the next canopy section into place per step 4. Make sure to butt this canopy section to the one just installed using 8" soft jaw clamps as required. See Figure 3.4. Affix the sections together by installing a lower tie-back bracket onto the holes drilled in the outriggers using the supplied #12 TEK screws. See Figure 3.5. With the lower tie-back bracket secured, repeat steps 6-7. Affix the back of each canopy section using a single #12 TEK screw per section. See Figure 3.6.
- Repeat steps 4-9 until all of the canopy sections are installed.
- Securely fasten the canopy bodies to the mounting rails using the remaining #12 TEK screws per Figure 3.6.
- Add flashing and sealant (supplied by others) to completely seal the joint between the canopy system and the building.



**Fig. 3.4 Canopy Clamping**



**Fig. 3.5 Bottom Tie-Back at Outriggers**



**Fig. 3.6 Final Canopy Assembly**